



TEREX | COMEDIL

CTT 181/B-8 TS21

Technical Specifications

- 1 SPECIFICATIONS SHEET**
- 2 CRANE CLASSIFICATION**
- 3 LOAD HANDLING DEVICES**
- 4 WORK ENVIRONMENT**
- 5 MAIN CRANE COMPONENTS**
- 5.1 DRIVE ASSEMBLIES (GENERAL INFORMATION)**

Chapter 2

Diagramma di portata **I** **Courbes de charges** **F** **Curvas de cargas** **E**
Load Diagram **GB** **Lastkurven** **D**

CTT 181/B-8														
		m	10	15	20	25	30	35	40	45	50	55	60	65
4 t	-	34.97	4,00	4,00	4,00	4,00	4,00	4,00	3,42	2,98	2,63	2,34	2,10	1,90
4 t	-	34	4,00	4,00	4,00	4,00	4,00	3,86	3,29	2,84	2,48	2,19	1,95	1,75
8 t	-	18.67	8,00	8,00	7,40	5,73	4,64	3,86	3,29	2,84	2,48	2,19	1,95	1,75
4 t	-	41.54	4,00	4,00	4,00	4,00	4,00	4,00	4,00	3,65	3,23	2,89	2,60	
4 t	-	39.67	4,00	4,00	4,00	4,00	4,00	4,00	3,96	3,44	3,02	2,68	2,40	
8 t	-	21.72	8,00	8,00	8,00	6,83	5,54	4,64	3,96	3,44	3,02	2,68	2,40	
4 t	-	44.14	4,00	4,00	4,00	4,00	4,00	4,00	4,00	3,91	3,46	3,10		
4 t	-	42.21	4,00	4,00	4,00	4,00	4,00	4,00	4,00	3,71	3,26	2,90		
8 t	-	23.08	8,00	8,00	8,00	7,31	5,95	4,98	4,26	3,71	3,26	2,90		
4 t	-	45.62	4,00	4,00	4,00	4,00	4,00	4,00	4,00	4,00	3,60			
4 t	-	43.67	4,00	4,00	4,00	4,00	4,00	4,00	4,00	4,00	3,86	3,40		
8 t	-	23.87	8,00	8,00	8,00	7,59	6,18	5,18	4,44	3,86	3,40			
4 t	-	45	4,00	4,00	4,00	4,00	4,00	4,00	4,00	4,00	4,00			
8 t	-	24.58	8,00	8,00	8,00	7,85	6,39	5,36	4,59	4,00				
4 t	-	40	4,00	4,00	4,00	4,00	4,00	4,00	4,00	4,00				
8 t	-	25.06	8,00	8,00	8,00	8,00	6,54	5,48	4,70					
4 t	-	35	4,00	4,00	4,00	4,00	4,00	4,00	4,00					
8 t	-	25.52	8,00	8,00	8,00	8,00	6,67	5,60						

Altre installazioni **I** **Autres implantations** **F** **Otras implantaciones** **E**
Other configurations **GB** **Aufstellmöglichkeiten** **D**

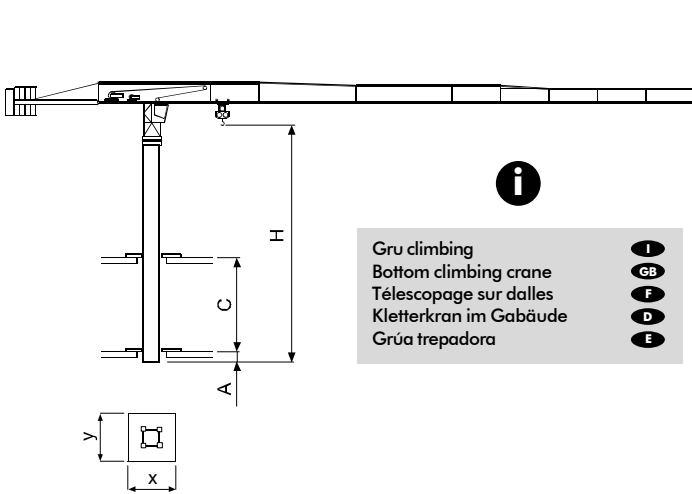

i

Gru climbing
 Bottom climbing crane
 Téléscoage sur dalles
 Kletterkran im Gebäude
 Grúa trepadora

I
GB
F
D
E

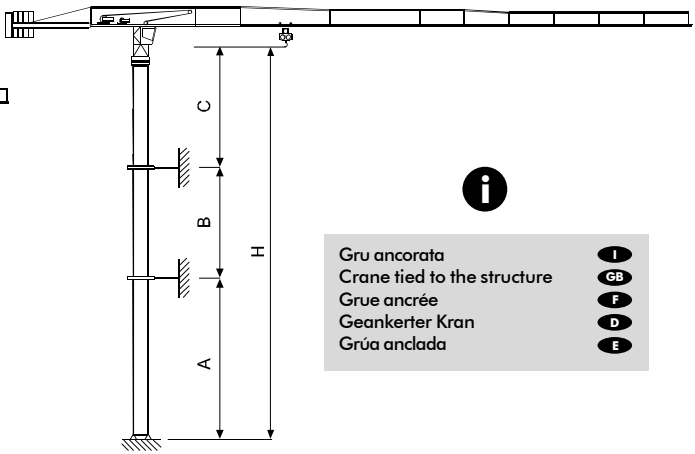

i

Gru ancorata
 Crane tied to the structure
 Grue ancrée
 Geankerter Kran
 Grúa anclada

I
GB
F
D
E

Gru "climbing" non disponibile (solo con torre TS21c)
 Bottom climbing crane not available (only with TS21c tower)
 Téléscoage sur dalles pas possible (seulement avec tour TS21c)
 Kletterkran im Gebäude nicht verfügbar (nur mit Turm TS21c)
 Grúa trepadora no disponible (sólo con torre TS21c)

I
GB
F
D
E

	TS 21 R ₃	TS 21 R ₄
	[m]	[m]
A _{min/max}	30 / 45	45 / 75
B _{min/max}	17.7/23.6	
C _{max}	35	35
H _{max}	I	I

Torre **I**

Tower **GB**

Tour **F**

Turm **D**

Torre **E**

TS21

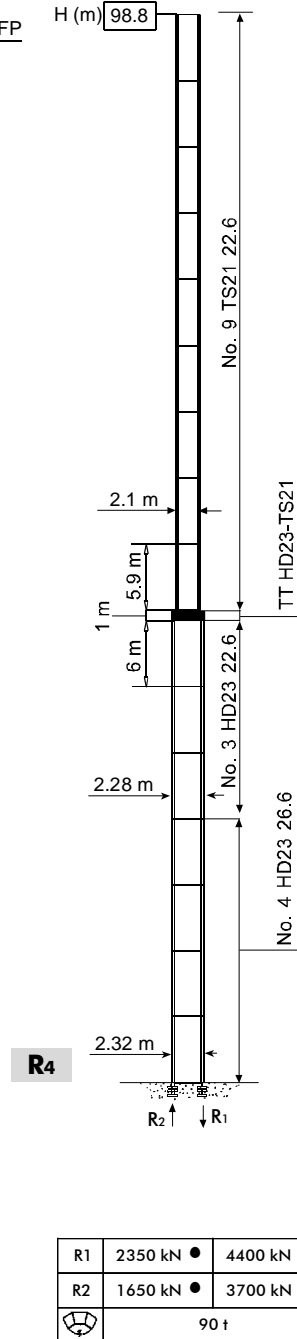
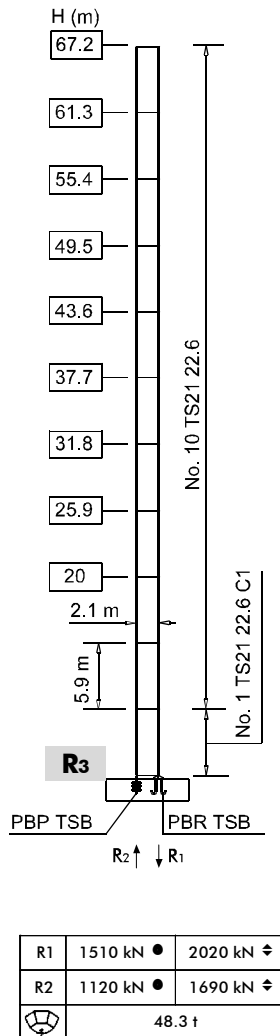
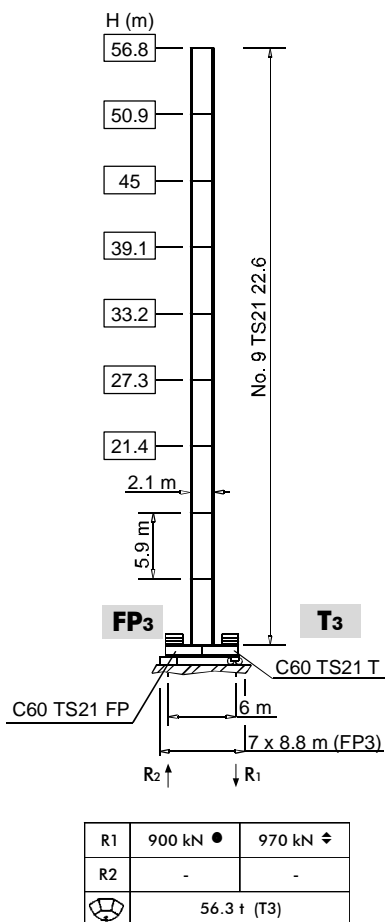
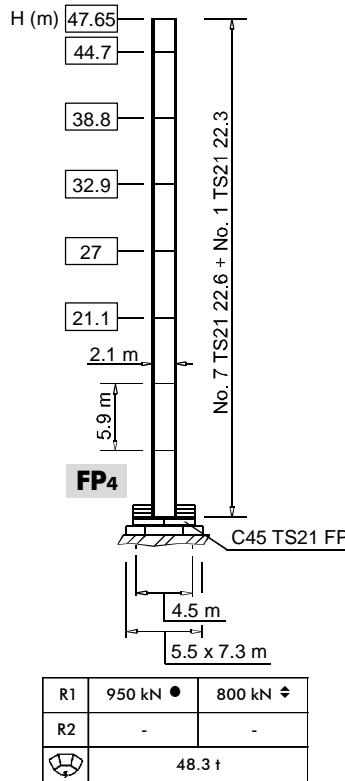
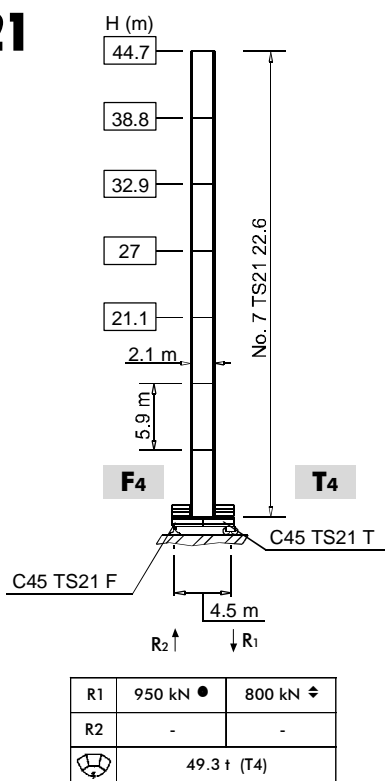

Los tramos de torre TS
 son disponibles en las medidas de largo 5.9 m, 2.95 m, 11.8 m. Maxima altura bajo gancho En servicio Fuera de servicio Sin carga, sin lastre, con pluma y altura máxima

Die Turmschüsse TS
 sind mit Längen 5.9 m, 2.95 m, 11.8 m verfügbar. Höchste Hackenhöhe In Betrieb Außer Betrieb Ohne Last und Ballast, mit Maximalausleger und Maximalhöhe

Les éléments de mât TS
 sont disponibles en longueur 5.9 m, 2.95 m, 11.8 m. Hauteur maxi: sous crochet En service Hors service A vide, sans lest, avec flèche et hauteur maximum

The available lengths for the TS tower sections
 are 5.9 m, 2.95 m, 11.8 m. Max. under hook height In service Out of service Without load, without ballast, max. jib and max. height

Le prolunghe TS
 sono disponibili in lunghezza 5.9 m, 2.95 m, 11.8 m. Altezza massima sotto gancho In servizio Fuori servizio A vuoto, senza zavorra, braccio max., altezza max.



Meccanismi	I	Mécanismes	F	Mecanismos	E
Mechanisms	GB	Antriebe	D		

70 * kVA	400 V - 50 Hz / 460 V - 60 Hz	2000/14/CE

* Gru senza traslazione / Crane without travelling equipment / Grue sans translation / Krane ohne Schienenfahren / Grúa sin traslación

		m/min	†	kW		
	30 AFC 40 D2 F12 30 AFC 40 D1 F12 LB 30 AFC 40 D1 F11 LB (VARIANT)		0 ⇨ 3	4	30	278 m (D2 F12)
			3 ⇨ 10	4		
			10 ⇨ 41	4		
			41 ⇨ 66	2.38		
			66 ⇨ 82	1.86		
			0 ⇨ 1.5	8		350 m (D1 F12 LB)
			1.5 ⇨ 5	8		
			5 ⇨ 20.5	8		
			20.5 ⇨ 33	4.76		
			33 ⇨ 41	3.72		

	DVF 3 5 D1 (VARIANT)	0 ⇨ 6 ⇨ 32 ⇨ 64 m/min		5 kW
	SSR 2 2 65	0.7 r.p.m. (50 Hz)	0.84 r.p.m. (60 Hz)	2 × 65 Nm
	▲ TAD 2RP 2M4	0 - 24 m/min		2 × 4 kW
	● TAD 2RG 4M3			4 × 3 kW

		▲	●
		Max. H [m]	
T₃	39.1	> 39.1	
T₄	32.9	> 32.9	

	Sollevamento	I	Hoisting	GB	Levage	F	Heben	D	Elevación	E
	Traslazione carrello		Trolleying		Distribution		Katzfahren		Distribución	
	Rotazione		Slewing		Orientation		Schwenken		Orientación	
	Traslazione		Travelling		Translation		Schienenfahren		Traslación	
	Direttiva sul livello acustico		Directive on noise level		Directive sur le niveau acoustique		Richtlinie für den Schall-Leistungspegel		Directiva sobre el nivel acustico	
	Consultateci		Consult us		Nous consulter		Auf Anfrage		Consultarnos	
	Potenza totale richiesta		Power requirements		Puissance totale nécessaire		Geforderte Stromstärke		Potencia necesaria	
	Alimentazione		Power supply		Alimentation		Stromversorgung		Alimentación	

Gru Comedil s.r.l.

A Terex Company



Via S. Egidio 42/A, 33074 Fontanafredda (PN) - Italy
Tel. (+39) 0434 567 311 - Telefax (+39) 0434 998631

Internet e-mail: info@comedil.com
Internet home page: www.comedil.com

Divisione Automontanti

Via Alessandrina, 25 - 20095 Cusano Milanino (MI) - Italy
Tel. (+39) 02 613 16011 - Telefax (+39) 02 613 16034

Internet e-mail: info.CBR@comedil.com

2

CRANE CLASSIFICATION

<i>Standards for structural calculations of the crane:</i>	FEM 1.001
<i>Machine grade:</i>	A3 (A2 for jibs)
<i>Standards for the electrical components:</i>	CEI - EN 60204 - 32

3

LOAD HANDLING DEVICES

8 t (17,640 lbs) - hook UNI 946 S / DIN 15401

4



WORK ENVIRONMENT

- Working temperature: **0 °C ➔ 40 °C** (upon the customer's request, cranes withstanding temperatures up to -20 °C can be supplied)
- Maximum relative humidity: **90%**
- Maximum wind speed:

<u>during assembly</u>	14	m/s	(~50 km/h)
<u>in service</u>	20	m/s	(~72 km/h)
<u>out of service</u>	42	m/s	(~150 km/h)



U.S. Customery units

- Working temperature: **32 °F ➔ 104 °F** (upon the customer's request, cranes withstanding temperatures up to -4 °F can be supplied)
- Maximum relative humidity: **90%**
- Maximum wind speed:

<u>during assembly</u>	46	ft/s	(~31 mph)
<u>in service</u>	66	ft/s	(~45 mph)
<u>out of service</u>	138	ft/s	(~93 mph)

- Maximum front surface:

the maximum admitted surface exposed to the wind in correspondence of the full load allowed at a certain jib length during hoisting is obtained by the ratio:

$$A = \frac{0.03 \times P}{q \times 1.2}$$

where

A = Front surface exposed to the wind [m²]

P = Weight of the load hanging from the hook [daN]

q = Pressure factor = $\frac{v^2}{16}$ [daN/m²]

v = Wind speed [m/s]



WARNING

The crane cannot be used in an explosive work environment or a work environment subject to fire risks. Also it cannot be operated in a work environment where flameproof devices are required.

5

MAIN CRANE COMPONENTS

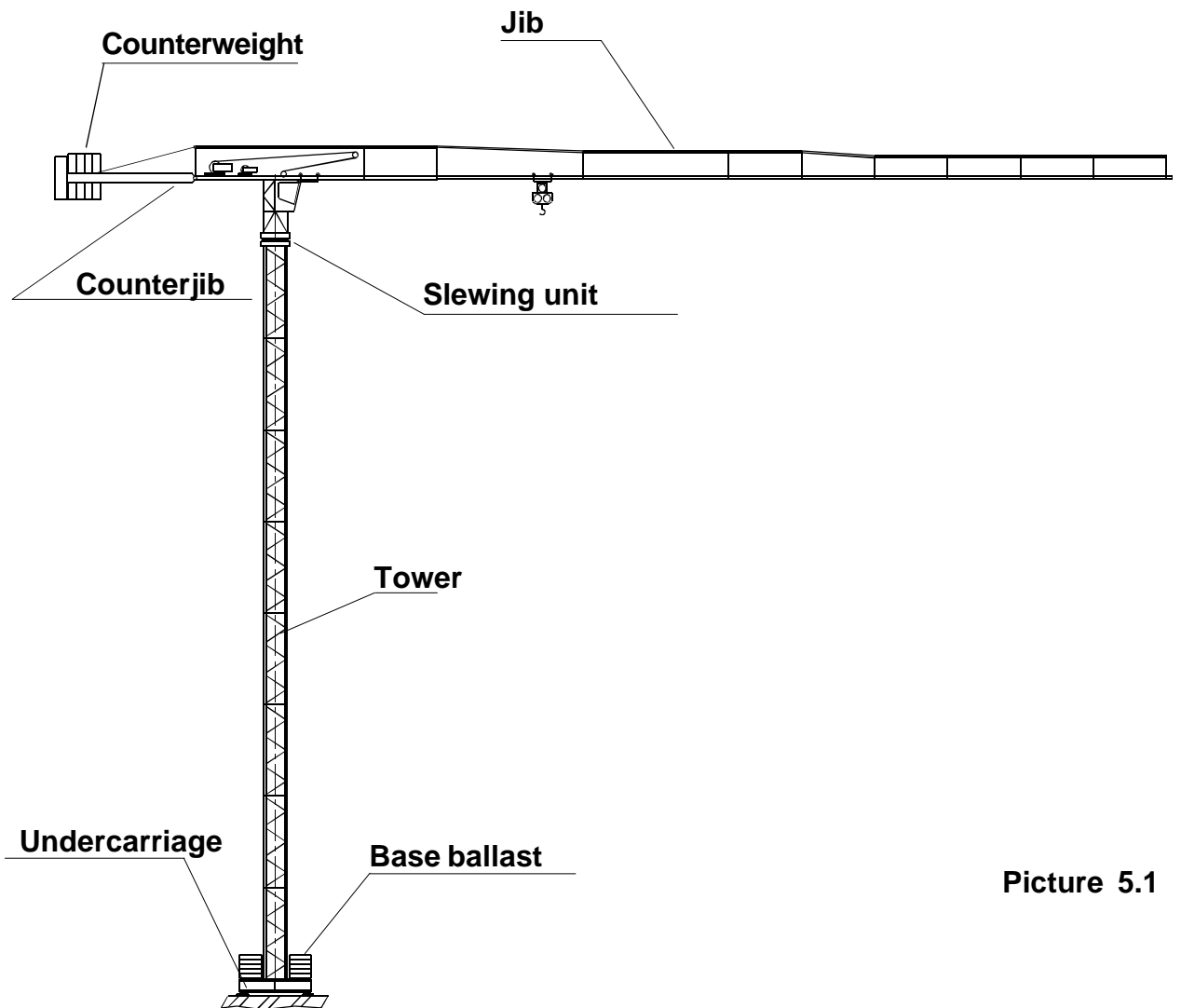

Picture 5.1

Undercarriage

The undercarriages studied for **TS21** towers are connected to the bottom mast section with no diagonal members.

There are three undercarriages available:

- “F”** fixed base on 4 support plates and adjustable screw jacks (base ballast placed on the undercarriage);
- “FP”** fixed base on 4 ballast blocks placed under the undercarriage edges and additional base ballast placed on the undercarriage;
- “T”** ballasted travelling platform mounted on trucks that ride along rails.

The undercarriages are made of a long beam connected to two short beams by vertical pins. The pin-connection is made at Comedil’s workshop, thus allowing transport of the unit in one single lot.

Interpret the undercarriages definitions shown in the specifications sheet as follows:

*Example > **C45 TS21 FP:** undercarriage with 4.5x4.5m (15x15 ft) gauge for TS21 tower (installation “FP”)*

Base ballast

Made of self-supporting reinforced concrete blocks, it consists of four additional special concrete blocks to be placed under and bolt-connected to the edges of the undercarriage (“**FP**” installation only).

Tower

“**TS**” towers are made of HE-sectioned stanchions and welded round-tube diagonals. The “*elephant foot*” connection used to join the mast sections is made of 2 special M48 bolts vertically placed on each stanchion.



Interpret the tower element definitions as follows:

Example 1:

TS 21 22.6 : tower element “TS” > width 21 dm (7ft) > stanchion flange thickness = 22 mm (0.9 in.) > height about 6 m (20ft)

Example 2:

TS 21 22.3 : tower element “TS” > width 21 dm (7ft) > stanchion flange thickness = 22 mm (0.9 in.) > height about 3 m (10ft)

Counterjib and Counterweight

Horizontal member of the crane supported by 2 tie-bars, on which the counterweight is mounted.

It is equipped with protected access footwalks to the counterweight and a movable work platform for making the assembly of the counterweights during the crane erection, easier.

There are two types of counterweights (both made, anyhow, of self-supporting reinforced concrete blocks) to be placed some in the special compartment and some in the ballast basket located on the rear of the counterjib.

For the right counterweight quantity and configuration, refer to **Chapter 3B - “Counterweights”** of the crane operation manual.

Slewing unit

It consists of the lower slewing ring support (connected to the tower) and the powered upper slewing ring support (rotating with the crane upper part) with the slewing ring placed in the middle.

The cab tower section rests on the upper slewing ring support.

Jib

Self-supporting type, it does not need any tie-bar and consists of 10 triangular sections and a jib point section.

Diagonals are made from round-hollow bars; the upper and lower longitudinal spars from square-hollow bars or square sections.

The first jib section partially acts as counterjib, as well (winches and limiters are mounted on it).

It is equipped with a safety cable, thus allowing the crane operators and maintenance engineers to fasten themselves by the special safety belt when walking along it.



Interpret the jib section definitions (see **Chapter 5B - “Slewing upper part erection”** of the crane operation manual) as follows:

Example : Jib Section 06

06 TT 11 16.05 : jib section identification number > Flat Top series jib section > jib section width 11 dm (4ft) > jib section height 16 dm (5ft) > jib section length 5 m (16ft).

5.1 DRIVE ASSEMBLIES (GENERAL INFORMATION)

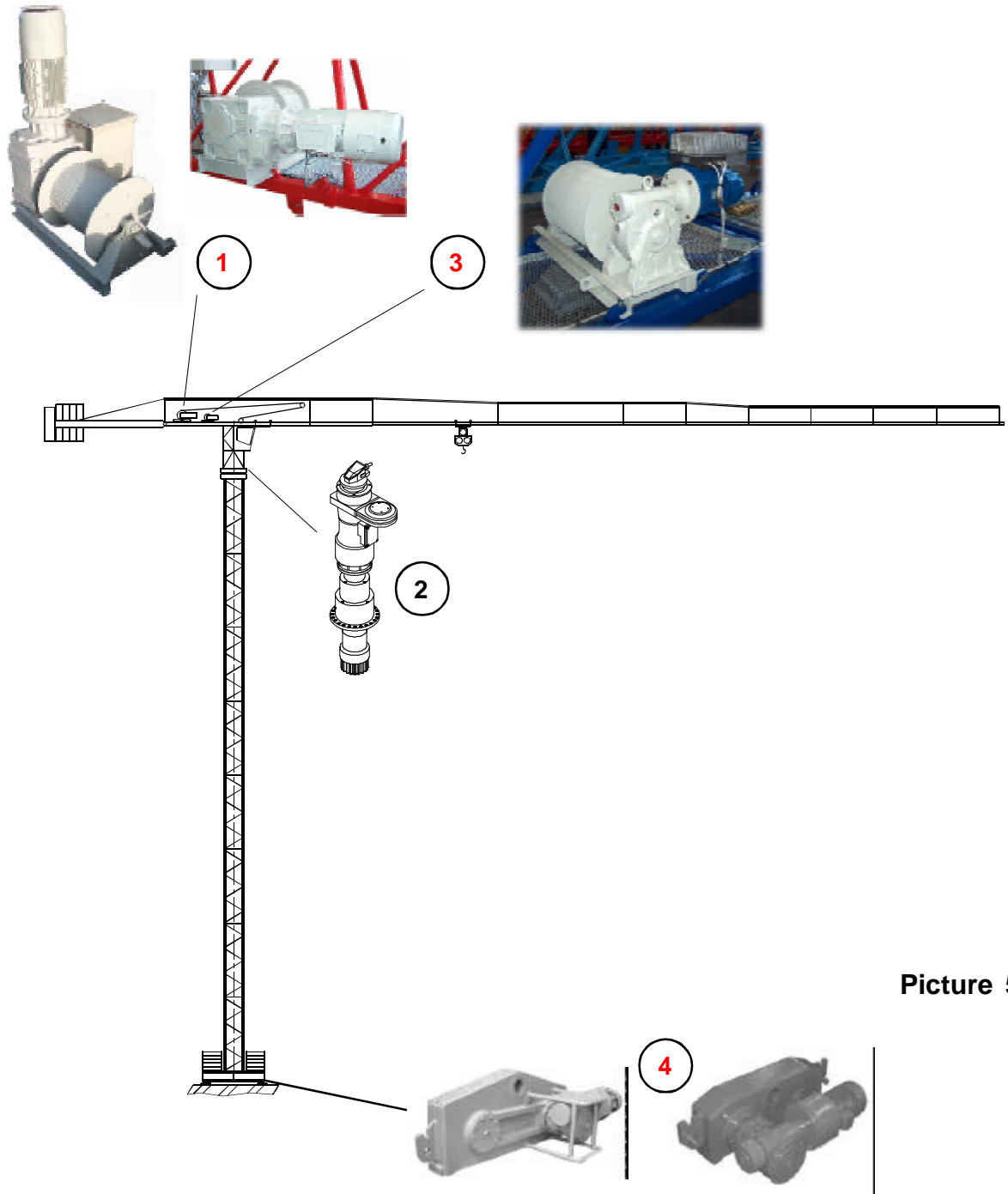

Picture 5.1.1

- | | |
|---|--|
| <p>1) HOIST WINCH</p> <p>2) SLEWING UNIT</p> <p>3) TROLLEY TRAVERSING WINCH</p> <p>4) TRAVELLING UNIT</p> | <p>➔ See Chapter 9 of the crane operation manual for technical specifications.</p> <p>➔ See Chapter 13 of the crane operation manual for technical specifications.</p> <p>➔ See Chapter 10 of the crane operation manual for technical specifications.</p> <p>➔ See Chapter 12 of the crane operation manual for technical specifications.</p> |
|---|--|