

S-65

3 - 6 ton

GRÚA TORRE TOWER CRANE GRU A TORRE

SAEZ

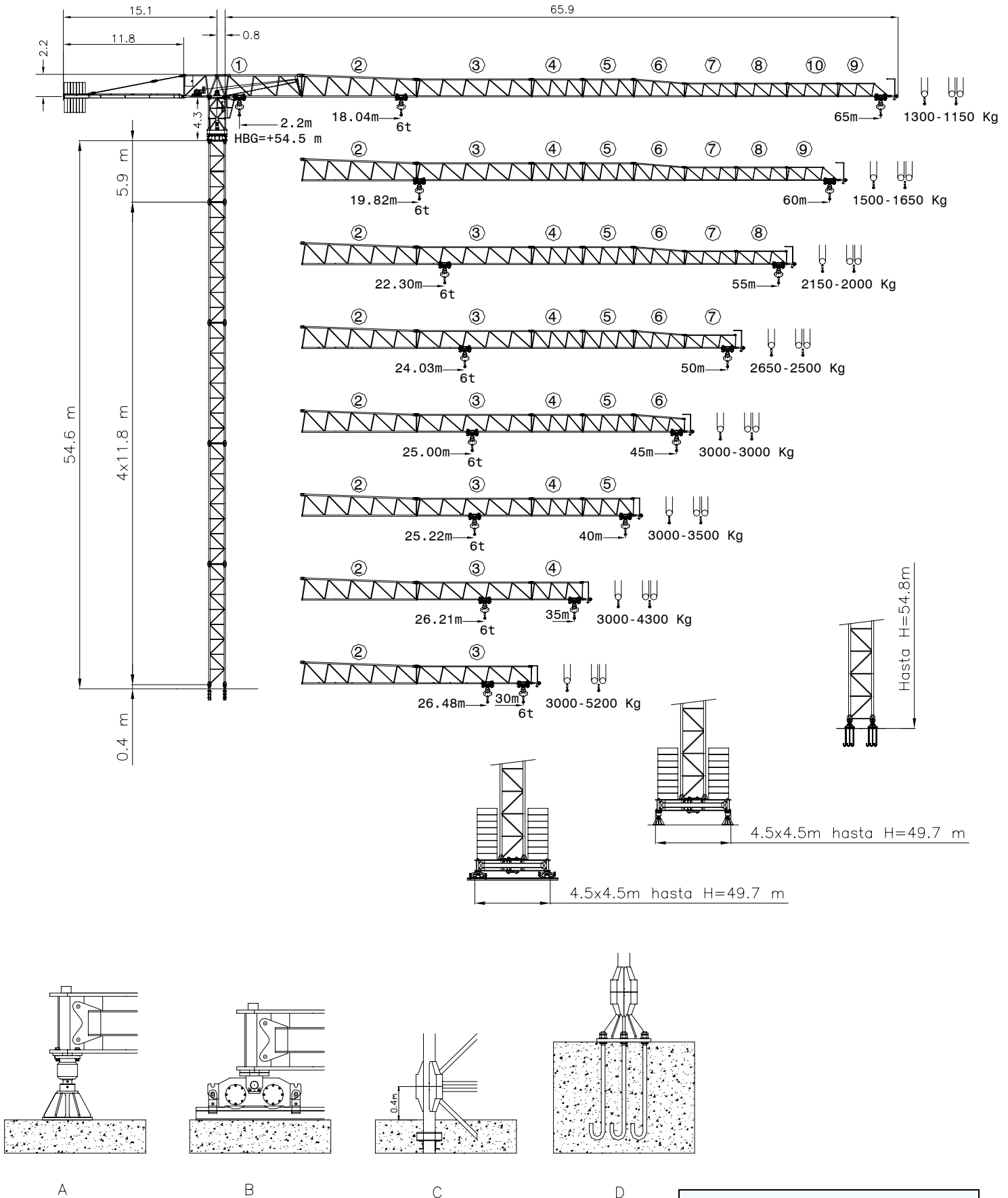

UNE 58-101-92 // FEM 1001-87
 Conforme con la directiva 98/37/CE
 According to EC 98/37 instruction
 Conforme alla direttiva 98/37/CE

DIN/FEM **CE**

S-65



3 - 6 ton



GRÚA TORRE TOWER CRANE GRU A TORRE



SAEZ

Alcance Radius Sbraccio (m)	Campo de Carga Max. Max swl range Campo di carico mass. 3000 Kg	65	60	55	50	45	40	35	30	25	20	15	10
		3000 kg	65	2.1-33.6	1300	1450	1630	1840	2110	2440	2860	3000	3000
60	2.1-37.0		1650	1850	2080	2370	2740	3000	3000	3000	3000	3000	3000
55	2.1-41.8			2150	2420	2750	3000	3000	3000	3000	3000	3000	3000
50	2.1-45.1				2650	3000	3000	3000	3000	3000	3000	3000	3000
45	2.1-45.0					3000	3000	3000	3000	3000	3000	3000	3000
40	2.1-40.0						3000	3000	3000	3000	3000	3000	3000
35	2.1-35.0							3000	3000	3000	3000	3000	3000
30	2.1-30.0								3000	3000	3000	3000	3000

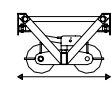
Alcance Radius Sbraccio (m)	Campo de Carga Max. Max swl range Campo di carico mass. 6000 Kg	65	60	55	50	45	40	35	30	25	20	15	10
		6000 kg	65	2.1-18.0	1150	1300	1480	1690	1960	2290	2710	3280	4090
60	2.1-19.8		1500	1700	1930	2200	2590	3060	3690	4580	5940	6000	6000
55	2.1-22.3			2000	2270	2600	3010	3540	4250	5260	6000	6000	6000
50	2.1-24.0				2500	2850	3300	3870	4640	5730	6000	6000	6000
45	2.1-25.0					3000	3460	4060	4860	6000	6000	6000	6000
40	2.1-25.2						3500	4100	4910	6000	6000	6000	6000
35	2.1-26.2							4300	5140	6000	6000	6000	6000
30	2.1-26.4								5200	6000	6000	6000	6000



CARGA / VELOCIDAD (kg/m/min) LOAD / SPEED - CARICO / VELOCITA'	
Potencia / Power / Potenza	33 Hp (24 Kw) 3 vel
	3000 kg - 8 m/min
	3000 kg - 37 m/min
	1500 kg - 74 m/min
	6000 kg - 4 m/min
	6000 kg - 18.5 m/min
	3000 kg - 37 m/min

MECANISMOS MECHANISMS / MECANISMI		
		
0.3 - 0.6 - 0.9 rpm	30 / 60 m/min	12 / 24 m/min
2 x 65 Nm	3Kw	4 x 3Kw

*** CARGA / VELOCIDAD (kg/m/min) LOAD / SPEED - CARICO / VELOCITA'	
Potencia / Power / Potenza	33 Hp (24 Kw) VF
	3000 kg - 0 ÷ 45 m/min
	2500 kg - 0 ÷ 50 m/min
	2000 kg - 0 ÷ 60 m/min
	1250 kg - 0 ÷ 100 m/min
	6000 kg - 0 ÷ 22.5 m/min
	5000 kg - 0 ÷ 25 m/min
	4000 kg - 0 ÷ 30 m/min
	2500 kg - 0 ÷ 50 m/min

ALCANCE Radius / Sbraccio		65	60	55	50	45	40	35	30
Contrapeso Aéreo Counterweight Contrappeso	Tipo	A	A	A B	A B	A B	A	A B	A
	Nº	7	7	6 1	5 2	5 1	5	4 1	4
	Kgs	17500	17500	16500	15500	14000	12500	11500	10000

LASTRE DE LA BASE Base Ballast Blocks Zavorra alla base		H (m)	14.3	20.2	26.1	32.0	37.9	43.8	49.7
	Ton	48	60	72	84	96	120	120	

*** CARGA / VELOCIDAD (kg/m/min) LOAD / SPEED - CARICO / VELOCITA'	
Potencia / Power / Potenza	45 Hp (33Kw) VF
	3000 kg - 0 ÷ 60 m/min
	2000 kg - 0 ÷ 80 m/min
	1250 kg - 0 ÷ 120 m/min
	6000 kg - 0 ÷ 30 m/min
	4000 kg - 0 ÷ 40 m/min
	2500 kg - 0 ÷ 60m/min

*** OPCIONAL
OPTIONAL
OPZIONALE

PESO DE CONSTRUCCIÓN APROXIMADO DEAD WEIGHT APPROX. / PESO DI COSTRUZIONE APPROSSIMATO		44.000 Kg
POTENCIA REQUERIDA Y CONDUCTORES Required Power and Conductors Potenza elettrica necessaria e conduttori	Con Elevación 24 Kw / 24 Kw Hoisting / Con sollevamento 24 Kw	
	44 KVA - 380 V - 50 Hz	
	25 m	100 m
	4x25mm ²	4x35mm ²

S-65

3 - 6 ton

GRÚA TORRE TOWER CRANE GRU A TORRE

SAEZ

COMPOSICIÓN DE TORRE / TOWER COMPOSITION / STRUTTURA DELLA TORRE

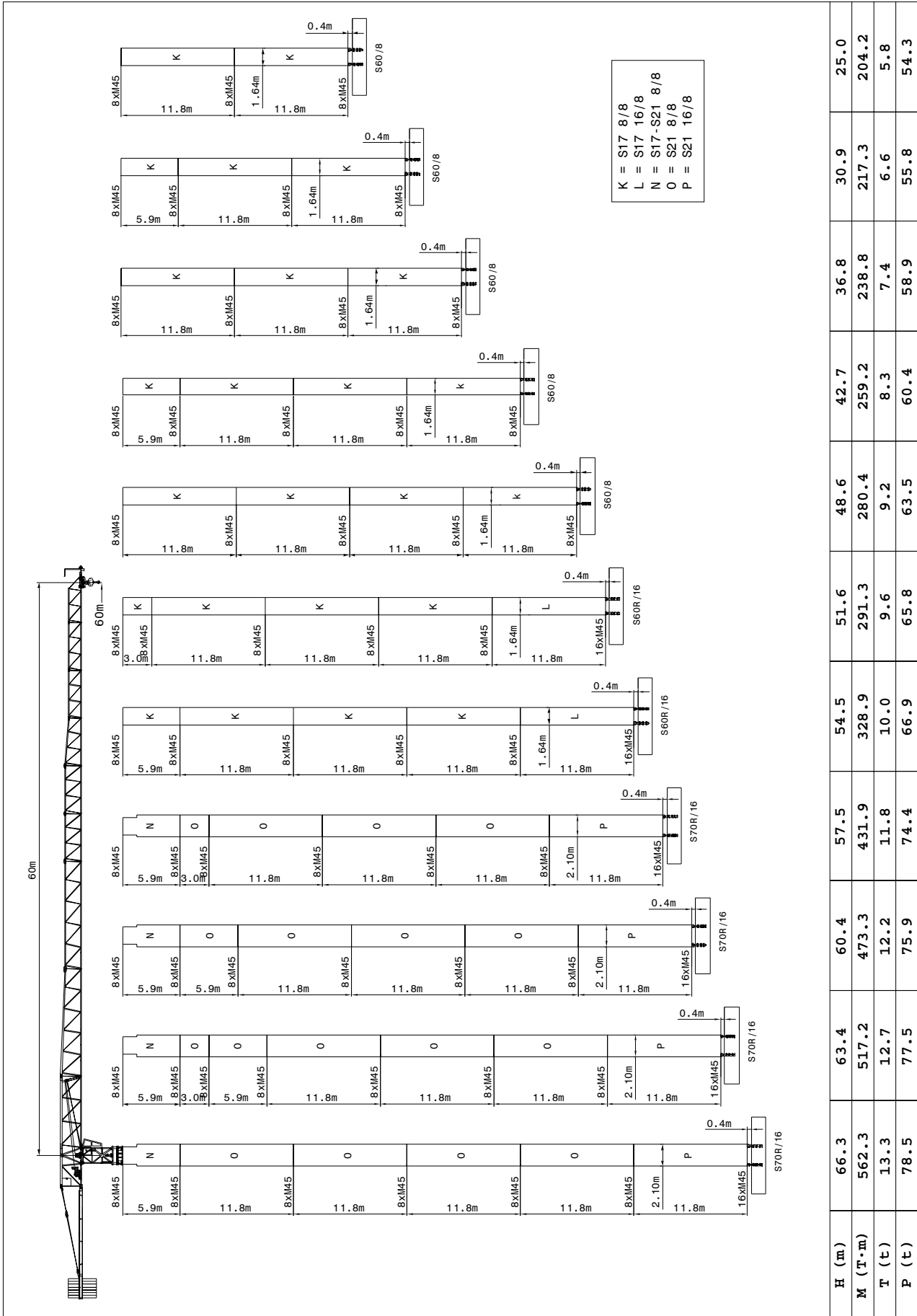





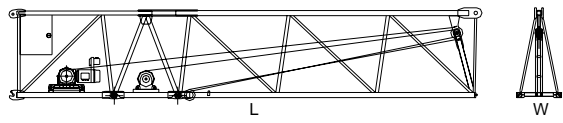
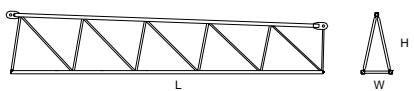
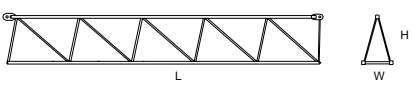
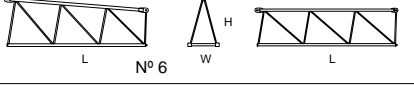
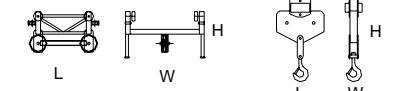
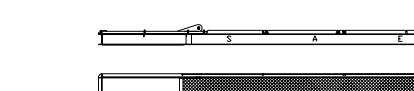

S-65

3 - 6 ton

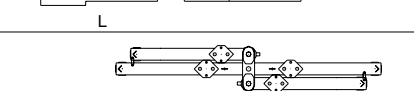
GRÚA TORRE TOWER CRANE GRU A TORRE

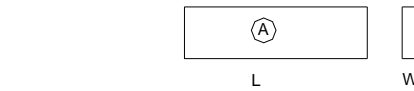
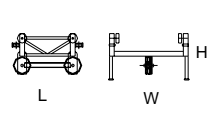
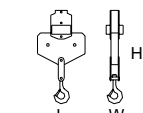
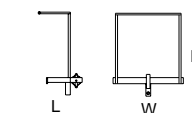
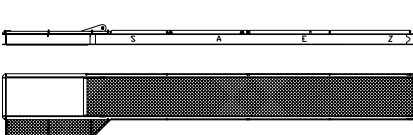
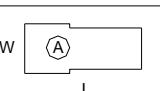
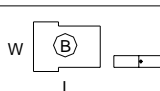
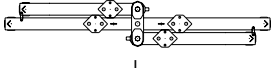
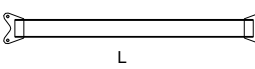
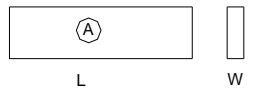
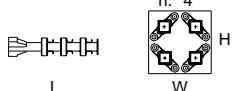
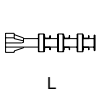
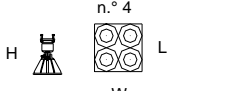
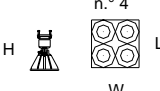
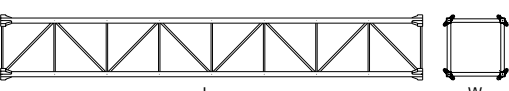
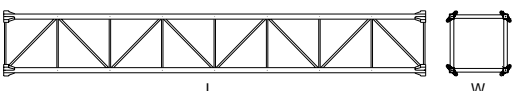
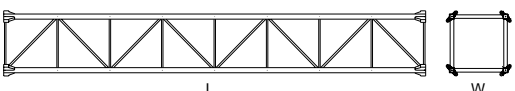
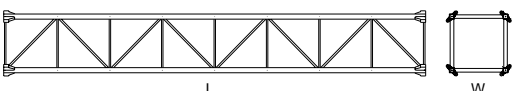
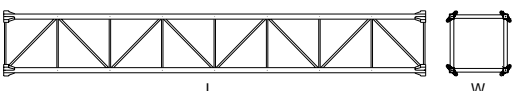
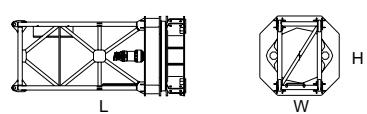
SAEZ

PESO Y DIMENSIONES DE LOS ELEMENTOS DE LA GRUA WEIGHT AND DIMENSIONS OF THE CRANE / PESO E DIMENSIONI DEI ELEMENTI DELLA GRU		L (m)	W (m)	H (m)	Peso (Kg)	
ELEMENTO DE PLUMA Nº 1 JIB HEEL SECTION ELEMENTO DI BRACCIO Nº1		11,90	1,25	2,30	5800	
ELEMENTOS DE PLUMA DEL Nº 2 AL Nº 9 JIB SECTIONS FROM 2nd TO 9th ELEMENTO DI BRACCIO DI 2º. Nº 9		2	11,60	1,13	2,25	2145
		3	11,60	1,13	1,80	1676
		4	5,30	1,13	1,80	596
		5	5,30	1,13	1,80	516
		6	5,30	1,13	1,80	444
		7	5,30	1,13	1,45	410
		8	5,30	1,13	1,45	320
		9	5,15	1,13	1,40	238
		10	5,30	1,13	1,40	280
	CARRO - GANCHO Y PUNTA TROLLEY - HOOK - JIB END CARRELLO, GANCIO E PUNTA		1,20	1,35	0,80	228
		0,80	0,15	1,50	267	
		0,80	1,20	1,40	75	
CONTRAPLUMA COMPLETA COUNTER JIB CONTROBRACCIO		11,80	1,80	0,60	2840	
BLOQUE DE CONTRAPESO COUNTERWEIGHT BLOCKS BLOCCO DI CONTRAPPESO		3,20	1,25	0,29	2500	
		1,83	1,25	0,29	1500	
BASE CRUCIFORME 4,5 X 4,5 CROSSBASE 4,5 X 4,5 CARRO BASE 4,5 X 4,5		6,70	1,10	1,20	5900	
VIGAS AUXIL. DE BASE HALF BASE BEAMS TRAVI DI CONGIUNZIONE		4,40	0,30	0,55	450	
BLOQUE LASTRE DE BASE BASE BALLAST BLOCKS BLOCCO DI ZAVORRA ALLA BASE		4,40	0,30	1,20	3800	
						
ELEMENTO EMPOTRE FOUNDATION ANCHOR EL ANNEGARE ELEMENTOS ATORNILLADOS TIED SECTIONS EL RECUPERABILE		1,50	0,70	0,70	750	
		1,35	1,35	0,60	1150	
NIVELADORES LEVELLERS PIEDI REGOLABILE TRASLACION TRAVELLING BOGIES TRASLAZIONE		1,20	1,20	0,90	1150	
		1,15	1,25	0,45	800	
ELEMENTO DE TORRE TL16 TOWER SECTIONS TL16 ELEMENTO DI TORRE		TL16	11,80	1,85	1,85	4600
		TR16	11,80	1,85	1,85	5740
		TS16	5,95	1,85	1,85	2450
		TC16	3,00	1,85	1,85	1380
UNIDAD DE ROTACION COMPLETE SLEWING UNIT ROTAZIONE		4,40	2,00	2,00	5900	
CABINA Y SOPORTE CABIN AND SUPPORT CABINA E SUPPORTO		3,00	1,15	2,35	400	

Sistemas Forza, S.L. Ctra. de Beniján, Km. 5 - Beniján - MURCIA (España)

Tlf: (+34) 968 82 08 62 / 66 - Fax: (+34) 968 82 48 57

forza@forzasl.com • www.forzasl.com

Sujeto a modificaciones / Subject to modifications! / Si fa riserva di modifiche!

Declinamos toda responsabilidad derivada de la información proporcionada

This information is supplied without liability / Le indicazioni contenute si intendono salvo errori ed omissioni